

Images SI Inc.  
109 Woods of Arden Road  
Staten Island NY 10312  
718.966.3694 Tel  
718.966.3695 Fax  
[www.imagesco.com](http://www.imagesco.com)

# Heatmobile



**Memory Metal Engine**

## **Instruction Manual**

**Images SI Inc. does not assume any responsibility for damages and injuries occurring due to the operation of this engine.**

**Before running the engine please read this instruction manual carefully.**

Attention: Heatmobile is not a toy and therefore not suitable for children. To avoid injuries be careful with the handling of the hot water.

## Introduction

The **Heatmobile** is a very special kind of heat engine that demonstrates the conversion of heat into mechanical energy. It uses a property of the metal alloy **Nitinol** (~50% **Nickel**, ~50% **Titanium**, the nol at the end of Nitinol refers to **Naval Ordnance Laboratory** in Maryland USA, where this alloy has been developed) called the “memory effect”. This effect can be generated by giving the alloy a heat treatment (about 600° C) and forming process to a special shape. Once impressed with a given shape the alloy tends to return abruptly to that given shape when heated above a transition temperature (in this application about 50° C to 70° C). Below this temperature the alloy is highly ductile and can be deformed with substantially less force than that developed by the material in returning to its trained shape.

## The Engine’s Concept

The design of the **Heatmobile** goes back to the ideas of Ronald H. Smith, Frederick E. Wang, A. D. Johnson and others. These inventors and scientists developed ideas to use the memory effect to build a new kind of heat engine. The **Heatmobile** consists of two pulleys connected by a closed loop memory metal wire. One pulley is partly running through a reservoir of hot water – the heat source. The other pulley is freely running and cooled by the surrounding air – the heat sink. The section of the memory metal wire that is dipped into the hot water tries to alter its shape to the trained form – a straight line - and generates a torque, that drives the related pulley and (by acting as a driving belt) the other one. This results in a continuous movement of the wire around the two pulleys transporting sections of the wire from the hot into the cold region and vice versa. During its return to the original shape in the hot region the wire is able to perform a considerable amount of work, greatly in excess of the work required to deform the wire in the cold region. The overall effect is the conversion of some fraction of the heat source’s thermal energy into mechanical work.

Because of the symmetry of the whole assembly the sense of rotation only depends on the initially given starting impulse.

# Assembly Drawing

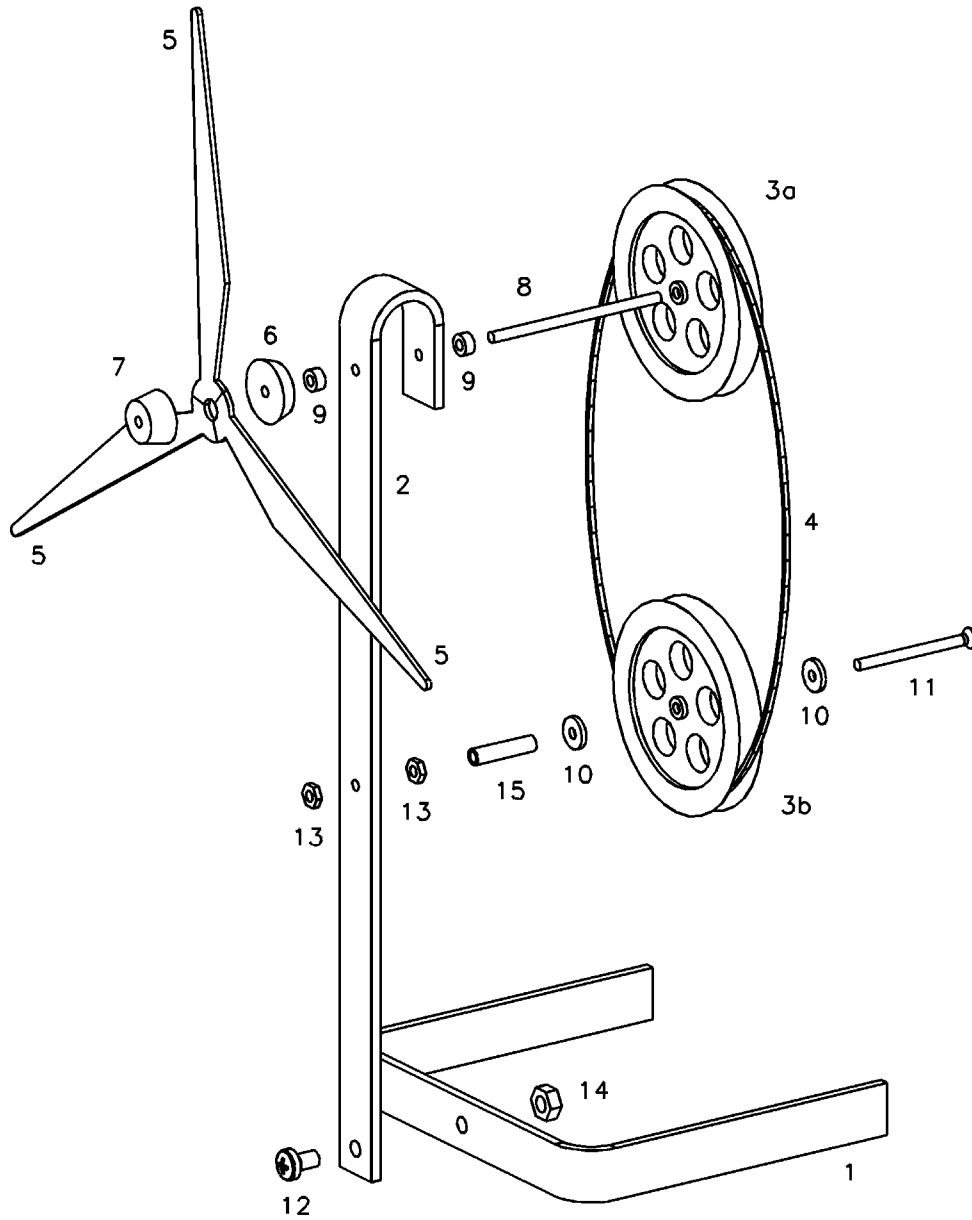

## Parts List

1	Base – U shaped
2	Pole
3a	Pulley A
3b	Pulley B with black mark
4	Memory metal wire
5	Propeller (3x)
6	Propeller base - rubber
7	Propeller top- rubber
8	Axle
9	Washer – plastic(2x)
10	Shim – metal (2x)
11	Screw M2x25
12	Screw M3x5
13	Nut M2 (2x)
14	Nut M3
15	Tube 13 mm

## Assembly Instruction

- 1) Fix the base (1) to the pole (2) with the screw (12) and the nut (14)
- 2) Pass the screw (11) through the first shim (10), the pulley B (3b), the second shim (10) and the tube (15) and connect it to the pole (2) using the two nuts (13)
- 3) Fix the three propellers (5) between the self sealing propeller base (6) and the propeller top (7) and press the axle (8) in the hole of the propeller base (6)
- 4) Pass the axle (8) through the first washer (9), the two holes in the pole (2) and the second washer (9)
- 5) Wrap the memory metal wire (4) around the lower fixed pulley (3b) and the other pulley (3a) and push the pulley (3b) on the open end of the axle (8). Be aware of an equal horizontal alignment of the two pulleys

## Operating Instructions

Place a suitable cup with hot water (~50°C) below the lower pulley. The pulley should dip into the water on a length of 5-10 mm. Flip the engine's propeller.

**Heatmobile** should start immediately with a rotational speed of about 200-400 rpm.

**Attention:** Handle memory metal wire with extreme care.

